

注意：产品安装使用前，请仔细阅读使用说明书，并妥善保管，以备查阅。

Note: Please read the operation instruction carefully before installing and using it, and please keep the instruction.

 **人民电器集团有限公司**
PEOPLE ELE. APPLIANCE GROUP CO.,LTD.

地址：浙江省乐清市柳市车站路555号 服务热线：400 898 1166

Address: No.555 Chezhan road, Liushi, Yueqing, Zhejiang, China. Telephone: 4008981166



使用说明书 Operation Instruction

ZN73-12系列户内高压真空断路器
ZN73-12 Indoor high voltage vacuum
circuit breaker

PEOPLE ELE. APPLIANCE GROUP CO.,LTD.

PEOPLE
ELECTRIC

ZN73(VS1)-12

B系列户内高压真空断路器 (B series indoor high voltage vacuum circuit breaker)



ZN73(VS1)B系列真空断路器为户内高压开关设备，适用于额定电压为12kV,频率50Hz三相交流电力系统中，作为保护和控制电器使用，特别适用于需要频繁操作的场所。

ZN73 (VS1) B series of vacuum circuit breaker is an indoor type high voltage switch equipment, suitable for rated voltage of 12kV, frequency of 50Hz three-phase AC power system, used as control and protection of electrical appliances, particularly applicable for frequent operations.)

1 概述

ZN73 (VS1) 型户内高压真空断路器 (以下简称断路器) 是用于12kV电力系统的户内开关设备,作为电网、工矿企业动力设备的保护和控制单元。由于真空断路器的特殊优越性,尤其适用于要求额定工作电流的频繁操作,或多次开断短路电流的场所。

断路器采用操动机构与断路器本体一体式设计,既可做固定安装单元,也可配用专用推进机构,组成手车单元使用。

ZN73 (VS1) indoor high voltage vacuum circuit breaker (hereinafter referred to as circuit breaker) is used for 12kV power system indoor switchgear, as the power grid, industrial and mining enterprises power equipment protection and control unit. Because of the special advantages of vacuum circuit breaker, it is especially suitable for the frequent operation of rated working current, or the place where the short-circuit current is broken off many times. The circuit breaker adopts the integral design of the actuating mechanism and the breaker body. The utility model can be used as a fixed installation unit or a special propulsion mechanism, and is composed of a handcart unit.)

2 型号的名称及含义

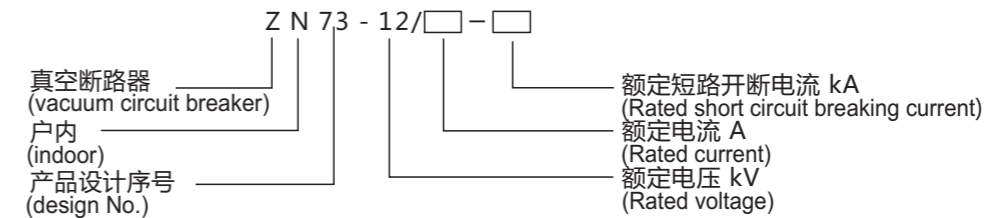

3 产品依据标准(Product standard)

断路器符合GB1984-2014《高压交流断路器》、JB3855-2008《3.6~40.5kV户内交流高压真空断路器》、DL/T403-2000《12kV~40.5kV高压真空断路器订货技术条件》标准要求,并符合IEC56(87出版物)的相关要求。

(The circuit breaker conforms to standard GB1984-2014 "high voltage AC breaker", "JB3855-2008 "3.6~40.5kV indoor AC high voltage vacuum circuit breaker," DL/T403-2000 "12kV~40.5kV high voltage vacuum circuit breaker order conditions" standard requirements, and in accordance with the relevant IEC56 (87 Publications) requirements.)

4 使用环境条件(Environmental condition:)

A.环境温度不大于+40°C,不低于-15°C(允许在-30°C时储运);→ Ambient temperature is within the range of -15°C~+40°C(permit preservation and transportation in -30°C)

B.海拔高度1000m;产品使用在7.2kV系统中时,适用海拔可提高达3000m;→ Altitude is up to 1000m;it can apply to altitude 3000m when using 7.2kV system.

C.空气相对湿度日平均值不大于95%,月平均值不大于90%;饱和蒸汽压日平均值不大于 2.2×10^{-3} MPa,月平均值不大于 1.8×10^{-3} MPa,在高湿度期内温度急降时,可能凝露;→ Air relative humidity's average is not more than 95% a day, not more than 2.2×10^{-3} Mpa a day, not more than 1.8×10^{-3} Mpa a month.

D.地震烈度不超过8级;→ Earthquake strength is not in excess of 8 degree.

E.无火灾、爆炸、严重污秽,化学腐蚀及剧烈震动的场所。→ Unsuitable for the location with combustible, explosive, heavy pollution and sharp pounding.

5 主要规格及技术数据:(Main specifications and technical parameters)

5.1 ZN73(VS1)真空断路器主要技术参数,见表1(The main technical parameters of ZN73 (VS1) vacuum circuit breaker are shown in Table 1):

表1 真空断路器主要技术参数(Table 1 main technical parameters of vacuum circuit breaker)

序号 (Serial No.)	名称(Description)		单位(Unit)	数据(Data)		
1	额定电压(Rated voltage)			12		
2	额定绝缘水平 Rated insulation level	1min, 耐压→Power-frequency 1 minute withstanding voltage	kV	42		
		额定雷电冲击耐压→Rated lightning impulse withstand voltage		75		
3	额定电流→Rated current		A	630 1250	630 1250 1600 2000 2500 3150	1250 1600 2000 2500 3150 4000*
4	额定短路开断电流→Rated short-circuit breaking current		kA	20 25	31.5	40
5	额定短路关合电流(峰值)→Rated short circuit closing current(Peak value)			50 63	80	100
6	额定动稳定电流(峰值)→Rated dynamic current(peak value)			50 63	80	100
7	额定热稳定电流(有效值)→Rated thermal stability current(virtual value)			20 25	31.5	40
8	额定短路电流开断次数→Rated short-circuit current breaking times		次time	50		30
9	额定热稳定时间→Rated thermal stability time		S	4		
10	额定操作顺序→Rated operating sequence			分-0.3S-合分-180S-合分→ O-0.3S-CO-180S-CO	分-180S-合分-180S-合分→ O-180S-CO-180S-CO	
11	机械寿命→Mechanical life		次	20000		
12	额定单个电容器组开断电流→Rated breaking current of single capacitor bank		A	630		
13	额定背对背电容器组开断电流→Rated breaking current of back to back capacitor bank			400		

5.2 断路器装配调整后,其机械特性参数应符合表2数据(After the circuit breaker is assembled and adjusted,its mechanical characteristic parameters shall conform to table 2 data)

表2 断路器机械特性参数(Mechanical characteristic parameters of circuit breaker)

序号 (Serial No.)	名称(Description)		单位(unit)	数据(date)	
1	触头开距→Contact open distance		mm	11±1	
2	超行程→Super travel			3.5±0.5	
3	三相分合闸不同期性→Unsynchronism of 3-phase Switchingin/switchingoff		ms	≤2	
4	合闸触头弹跳时间→Bouncing time of switchingin contact			≤2	
5	相间中心距离→Alternatly center distance		mm	210±1.5	275±1.5
6	合闸触头接触压力→Contact pressure of switchingin contact	20kA	N	2000±200	
		25kA		2400±200	
		31.5kA		3100±200	
		40kA		4250±250	
7	平均分闸速度→Average speed of switching off		m/s	0.9~1.3	
8	平均分闸速度→Average speed of switching in			0.5~0.8	
9	分闸时间→switching off time		ms	≤50	
10	合闸时间→Switching in time			≤100	
11	接触电阻→Contact resistance	630-1250	μn	≤50	
		1600-2000		≤45	
		2500-4000		≤40	

5.3 储能电机(Energy storage motor)

采用永磁式单相直流电动机,其技术数据见表3→It is adopt by permanent-magnet single-phase DC motor, and the technique data see the table 3.

表(Table)3

型号→Type	额定电压→Rated voltage (V)	额定输入功率→Rated input power (W)	正常工作电压范围额定电压→normal wokqing voltage range (V)	额定电压下储能时间→Stored energy time under the rated voltage (S)
ZYJ55- I	DC110 DC220	50 70	85%~110%额定电压(rated voltage)	≤15

注:操作电压允许采用交、直流电源。(Note: AC and DC power supply is allowed for operation voltage.)

5.4 分、合闸线圈的技术数据见表4(The technical data of the split and close coils are shown in Table 4)

表(Table)4

	合闸线圈→Switchingin coil	分闸线圈→Switchoff coil
额定操作电压→Rated operating voltage (V)	DC220,DC110 AC220,AC110	DC220,DC110 AC220,AC110
线圈功率→Coil power (W)	264	264
正常工作电压范围→Normal working voltage range	85%~110%额定电压(rated voltage)	65%~120%额定电压(rated volaage)

6 结构及特点(Structure and characteristic):

a.ZN73(VS1) 户内高压真空断路器配用中间封接式陶瓷真空灭弧室,采用铜铬触头材料,杯状纵磁场触头结构,其触头的电磨损速率小,电寿命长,触头的耐压水平高,介质绝缘强度稳定,弧后恢复迅速,截流水平低,开断能力强。→ZN73(VS1)indoor high voltage vacuum circuit breaker equips with middle sealing ceramics vacuum arc extinction room made in Cu-Cr,cyathiform longitudinal magnetic field contact structure, less electrical wear velocity of contact, long electrical life,high withstanding voltage level of contact, stable of medium insulating strength, resume quickly after arc, less cut current and strong cutoff ability.

b.ZN73(VS1) 真空断路器总体结构采用操动机构和灭弧室前后布置的形在式,主导电回路部分为三相落地式结构,真空灭弧室纵向安装一个管状的安装筒内,安装筒由环氧树脂采用APG工艺浇注而成,因而它特别抗爬电。这种结构设计,大大地减少粉尘在灭弧室表面聚积,不仅可以防止真空灭弧室受到外部因素的损坏,而且可以确保即使在湿热及严重污秽环境下,也可对电压效应呈现出高阻态。→ZN73 (VS1) is the overall structure of the vacuum circuit breaker with actuator and arc quenching chamber before and after arranged in shape, the main circuit part of three-phase floor type structure, the installation of a tubular cylinder vertical installation of vacuum interrupter, installation of cylinder made of epoxy resin by APG process casting, so it is extremely resistant to creepage. The structure design, greatly reduce the dust in the arc chamber surface accumulation, not only can prevent the vacuum interrupter damaged by external factors, but also can ensure that even in the humid environment and serious pollution, also showed a high resistance to voltage effect.

c.操动机构为平面布置的弹簧储能机构,具有手动储能和电动储能功能,操动机构置于灭弧室前的机箱内,机箱被四块中间隔板分成五个装配空间,其间分别装有操动机构的储能部分,传动部分,脱扣部分和缓冲部分,ZN73(VS1) 真空断路器将灭弧室与操动机构前后布置组成统一整体,即采用整体型布局,这种结构设计,可使操作机构的操作性能与灭弧室开合所需性能更为吻合,减少不必要的中间传动环节,降低了能耗和噪声,使断路器的操作性能更为可靠。断路器既可装入手车式开关柜,也可装入固定式开关柜。→Operating mechanism is plan layout spring stored energymechanism, it have manual and auto drive stored enery. Operating mechanism setted in the machine case in front of arc extinction room. The mechine case is partitioned into 5 assmly space by middle clapboard which respectively is stored enery part, gearing part, tripping part and amortizee part. ZN73(VS1) make the arc extinction room and operating mechanism a whoe, that just means adopting unitary setting. This structure design will make the operating ability of circuit breaker more reliable by reducing the needless middle gearing part, descending the energy consumption and noise.The circuit breaker can be insatllled not only in handcart switchboard but also in fixed switchboard.

d.该断路器具有寿命长、维护简单、无污染、无爆炸危险,噪音低等优点,并且适用于频繁操作等比较苛刻的工作条件。→There many excellences of the circuit breaker such as long life, easy maintenance, no pollution, no explosio and low noise, etc. It is suitable for the rigorous working condition just like frequency operate.

7 工作原理(Operational principle)

7.1 灭弧原理(Arc extinction principle)

断路器采用真空灭弧室，以真空作为灭弧和绝缘介质，灭弧室具有极高的真空度。当动、静触头在操动机构作用下带电分闸时，在触头间将会产生真空电弧。同时，由于触头的特殊结构，在触头间隙中也会产生适当的纵磁场，促使真空电弧保持为扩散型，并使电弧均匀地分布在触头表面燃烧，维持低的电弧电压。在电流自然过零时，残留的离子、电子和金属蒸汽在微秒数量级的时间内就可复合成凝聚在触头表面和屏蔽罩上，灭弧室断口的介质绝缘强度很快被恢复，从而电弧被熄灭，达到分断的目的。由于采用纵磁场控制真空电弧，所以本真空断路器具有强而稳定的开断电流能力。→The circuit breaker adopts vacuum arc extinction room which make the vacuum as arc extinction and dielectric medium. The arc extinction room have high vacuum degrree. Whe moving contact and fixed contact switchingoff under the operatingmechanism, it will bring vacuum electric arc between the contacts. At the same time, it will bring proper longitudinal magnetic field between the contacts which make the vacuum electric arc kept divergent mode and keep low electric voltage by equably burning the electric arc on the surface of the contact for the special structure of contact. There is strong and stable breaking current abliity of the vacuum circuit breaker for controlling the vacuum electric arc with longitudinal magnetic field.

7.2 动作原理(Operating principle)

图1, 图2, 为机构动作的结构简图→chart 1 and chart 2 are the structrue diagrams of mechanism operating.

7.2.1 储能动作(Stored energy operating)

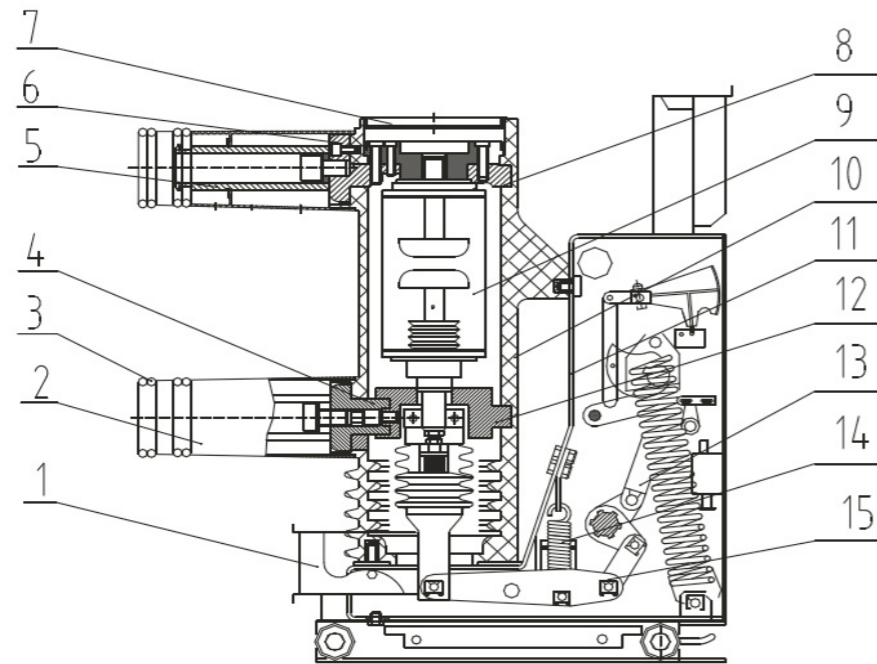

- | | |
|----------------------------|--|
| 1.导板 (Fence plate) | 9.灭弧室组件 (Arc extinguishing chamber assembly) |
| 2.套管(Bushing) | 10.绝缘筒(Insulating cylinder) |
| 3.梅花触头 (Plum contact) | 11.框架(Frame) |
| 4.下引出线 (Lower lead line) | 12.下支架(Lower bracket) |
| 5.触臂 (Contact arm) | 13.合闸传动(Closing the transmission) |
| 6.上引出线 (Upper lead line) | 14.合闸弹簧(Closing spring) |
| 7.盖子 (Lid) | 15.拐臂组件(Turn the arm components) |
| 8.上支架 (Upper bracket) | |

图1 ZN73-12型户内高压真空断路器内部侧面结构图
(Figure 1 Internal side view of N73-12 type indoor high voltage vacuum circuit breaker)

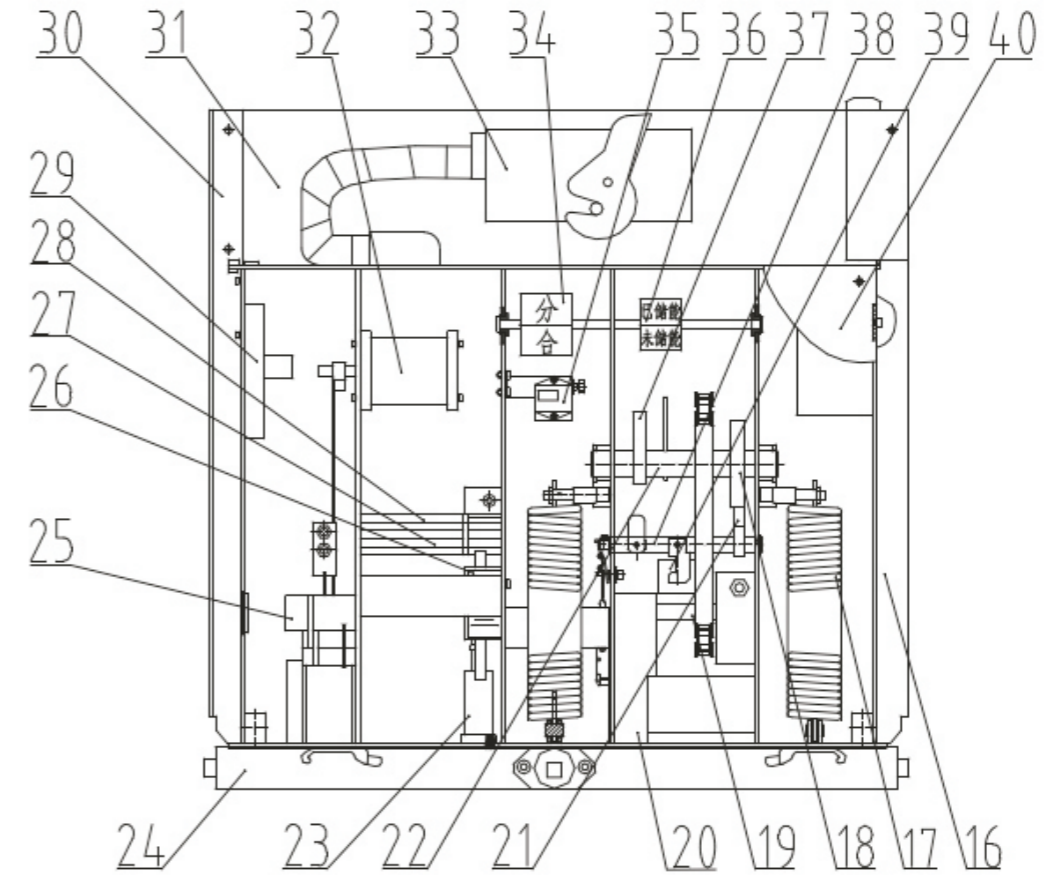

- | | |
|--------------------------------|---|
| 16.边板(Side plate) | 29.整流板 (contra-propeller) |
| 17.合闸弹簧(Closing spring) | 30.边板 (Side plate) |
| 18.储能系统(Energy storage system) | 31.端板 (End plate) |
| 19.电机输出轴(Motor output shaft) | 32.辅助开关 (Auxiliary switch) |
| 20.储能电机(Energy storage motor) | 33.二次插头座 (Two time plug seat) |
| 21.保持掣子(Hold latch) | 34.分合指示牌 (Split indicator) |
| 22.储能轴(Energy storage shaft) | 35.计数器 (Counter) |
| 23.油缓冲器(Oil buffer) | 36.储能指示牌 (Energy storage indicator board) |
| 24.底盘车(Chassis) | 37.合闸凸轮 (Closing cam) |
| 25.主轴(Principal axis) | 38.合闸半轴 (Closing axle) |
| 26.分闸脱扣器(Tripping release) | 39.合闸脱扣器 (Closing release) |
| 27.分闸掣子(Brake pawl) | 40.操作面板 (Operation panel) |
| 28.分闸半轴(Split axle shaft) | |

图2 ZN73-12户内高压真空断路器正面结构图
(Figure2 ZN73-12Front structure diagram of indoor high voltage vacuum breaker)

储能电机20输出扭矩通过单向轴承传动,带动储能系统18运动,推动储能轴22旋转,驱动储能轴上的挂弹簧拐臂转动,从而拉长合闸弹簧17,达到储能目的,当合闸弹簧储能完成后,能量由储能保持挚子21保持住。与此同时,储能指示36带动储能微动开关动作,切断储能电机的电源,完成整个储能动作。→The output torque of stored energy motor 20 will transit by chain drive through one way bearing 18,make driving paw22 run, push energy shaft 22 circumrotate, drive the hanging spring oscillating arm of theenergy shaft running, draw out the switchingin spring 17 and make it store the enerfy. After the switchingin spring has stored the energy, the energy will be kept by stored energy holding element 21. At the same time,stored energy pointer 36 make stored energy sensitive switch operate, cut off the power supply of the stored energy motor. That is the whole stored energy process.

7.2.2 分,合闸动作(Switching/off and switching/on operating)

a.合闸动作(Switching/on operation)机构储能后,若接到合闸信号,合闸脱扣器39的动铁芯将被吸合向前运动,促使合闸半轴38作顺时针方向转动。从而解除了储能保持挚子21对储能轴22的约束,合闸弹簧17的能量释放,使合闸凸轮37作顺时针方向转动,通过一级四连杆传动机构13及绝缘拉杆15带动真空灭弧室的动导电杆向上运动,完成合闸动作。→after the mechanism stored the energy, the moving iron core of switchingin trip 39 will acctract forward and make the switchingin semi axis 39 clockwise turn as soon as receive the switchingin signal. It makes the stored energy shaft 22 free from the stored energy holding element 21,release the energy of the switchingin spring 17,make the switching cam 37 clockwise turn,drive the moving electric conduction pole of vacuum arc extinction room 3 to upward move through the first level four connecting rod gearing drive 13 and insulation draw bar 15, and complete the switchingin operating.

b.分闸动作(Switching/off operation)

合闸动作完成后,分闸脱扣器26一旦接到分闸信号,脱扣半轴28在脱扣力的作用下逆时针转动,半轴对分闸挚子27的约束解除,分闸脱扣部分在断路器的触头压力弹簧和分闸弹簧的作用下,作逆时针方向转动,真空灭弧室9的动导电杆在一级四连杆机构13及绝缘拉杆15的带动下向下运动,从而完成分闸动作。→ After completeing the switching/on operating, the brake release 26 once received off signal, the trip semi axis 28 in the tripping force under the action of anti clockwise half shaft on the brake pawl 27 of the constraint release,release braking part in contact pressure spring breakers and brake spring. For,as the counter clockwise rotation,the vacuum interrupter 9 of the movable conducting rod in a four rod mechanism 13 and the 15 drive insulating rod moves downward, thus completing the tripping action.

8 ZN73型断路器外边尺寸图见图3~图6(The outer dimensions of type ZN73 circuit breakers are shown in chart3~, chart 6)



图3 800mm柜固定式断路器外形尺寸 (800mm Fixed circait breaker)



注:手车推进程200mm→Note:handcart propulsion 200mm

图4 800mm柜抽屉式断路器外形尺寸 (800mm Drawertype breaker)

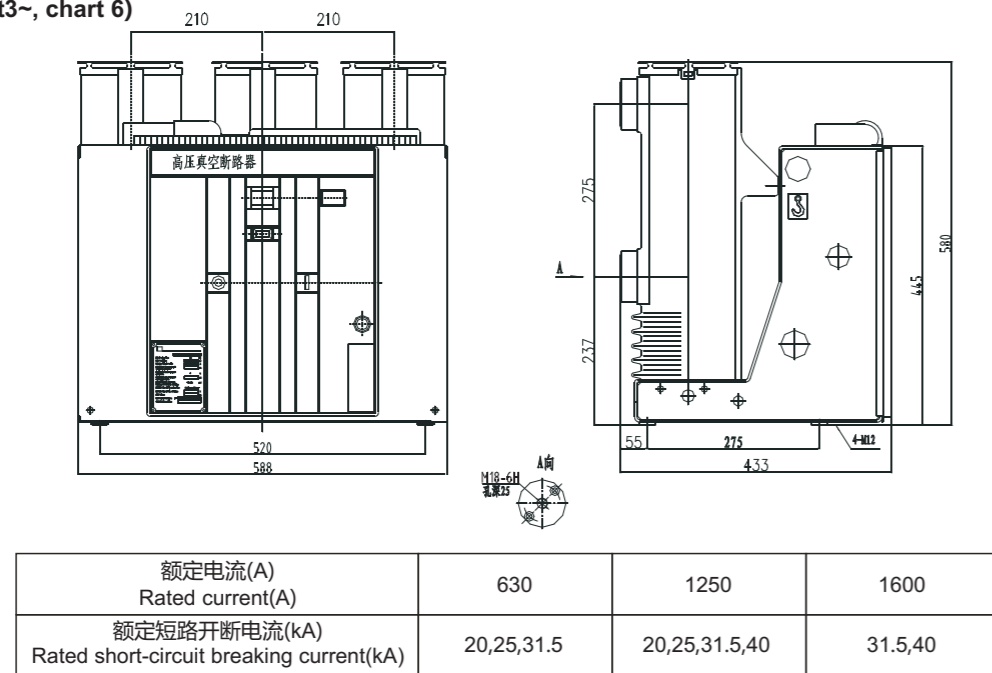
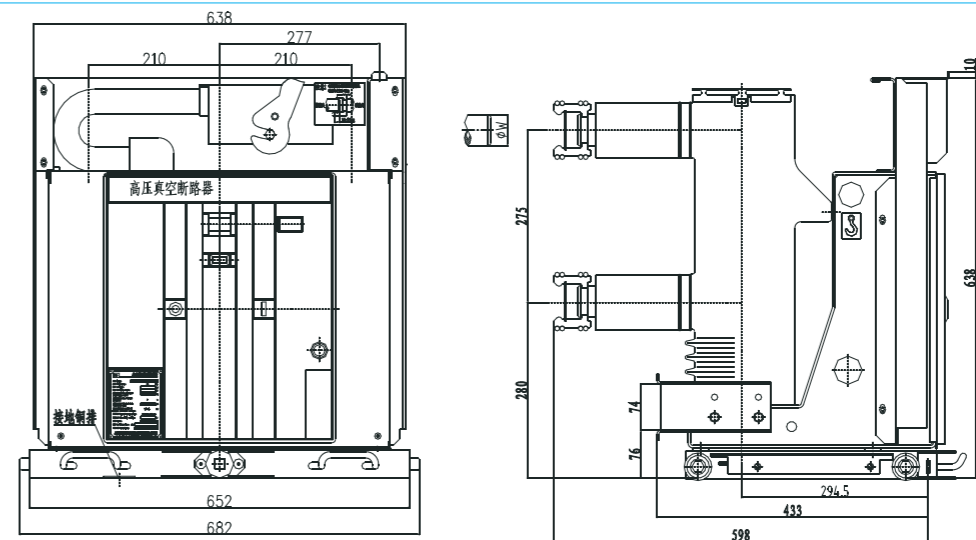

图5 1000mm柜固定式断路器外形尺寸 (1000mm Fixed circait breaker)



额定电流(A) Rated current(A)	1600	2000	2500	3150,4000
额定短路开断电流(kA) Rated short-circuit current(kA)	40	31.5,40	31.5,40	31.5,40
配合静触头尺寸(mm) Fit static contact size(mm)	φ 79			

注：手车推进程200mm→Note:handcart propulsion 200mm

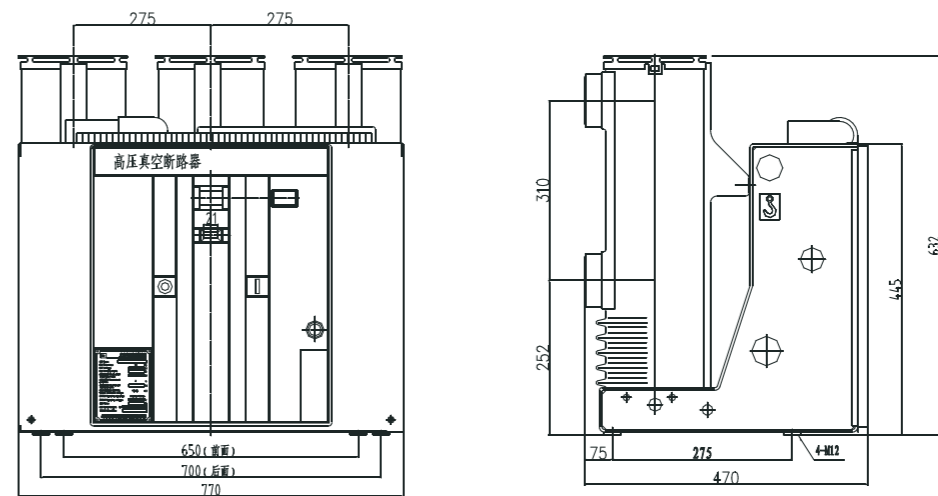
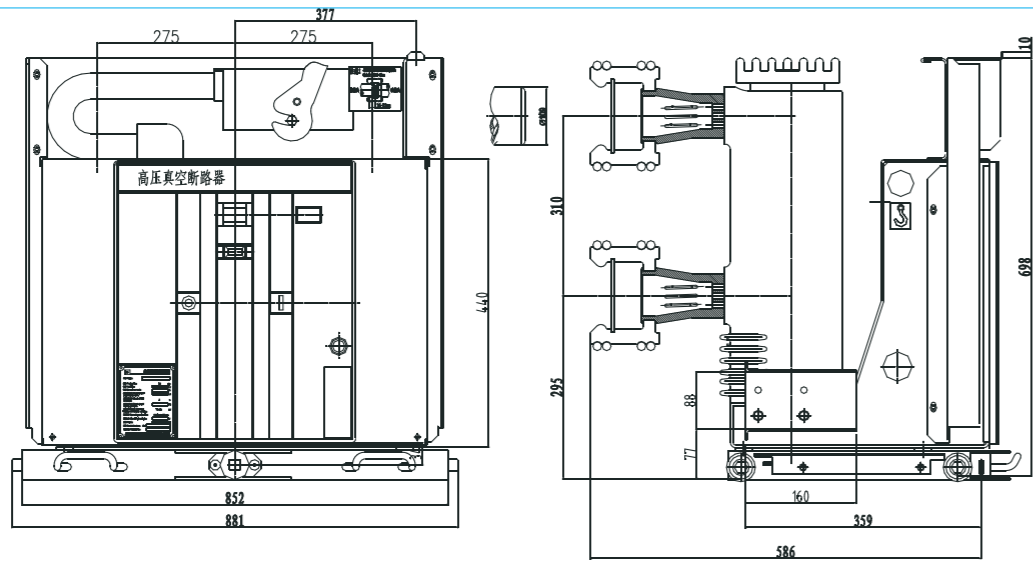
图6 1000mm柜抽屉式断路器外形尺寸 (1000mm Drawertype breaker)

9 断路器的电气原理接线图见图7-图12(The wiring diagram of the breaker's electrical principle is shown in figure 7-, Figure 12)

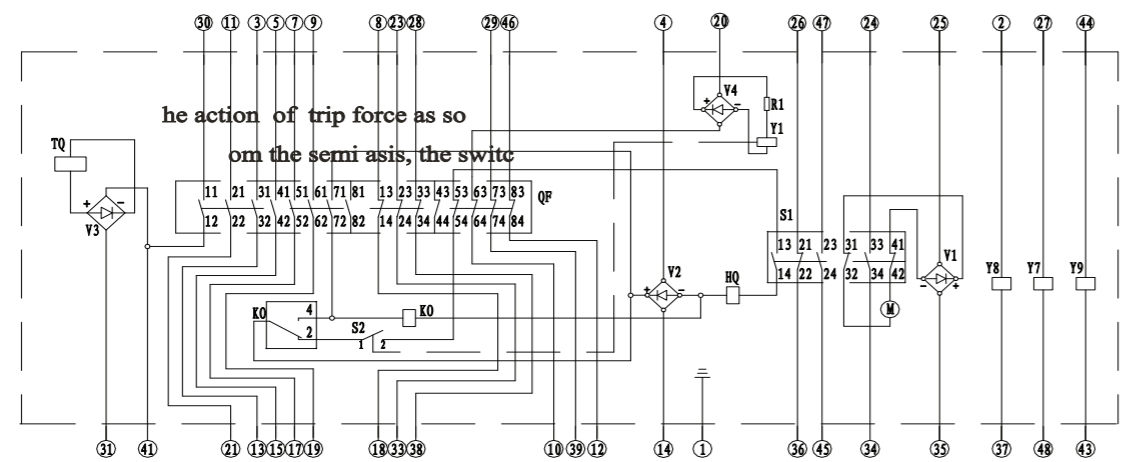

Y1: 闭锁电磁铁 (Latching electromagnet)
Y7~Y9: 过电流脱扣电磁铁 (Over-current tripping electromagnet)
KO: 机构内部防跳继电器 (Anti jump relay in mechanism)
HQ: 合闸电磁铁 (Closing electromagnet)
S2: 闭锁电磁铁行程开关 (Locking electromagnet travel switch)
M: 储能开关 (Energy storage switch)
S1: 储能用微动开关 (Micro switch for energy storage)
QF: 断路器主触头的辅助开关 (Auxiliary switch for main contact of circuit breaker)
Tq: 分闸电磁铁 (Brake electromagnet)

图7 固定式断路器电气原理图
Chart 7 Electrical diagram of fixed circuit breaker

II	1 接地	26 1-21
	2 12-1	27 11-1
	3 5-31	28 5-33
	4 A-5	29 5-73
	5 5-41	30 5-11
	6	31 A-2
	7 5-51	32
	8 5-13	33 5-24
	9 5-61	34 1-34
	10 5-64	35 A-1
	11 5-21	36 1-22
	12 5-84	37 12-2
	13 5-32	38 5-34
	14 A-6	39 5-74
	15 5-42	40 接地
	16	41 5-12
	17 5-52	42
	18 5-14	43 13-1
	19 5-62	44 13-2
	20 A-13	45 1-24
	21 5-22	46 5-83
	22	47 1-23
	23 5-23	48 11-2
	24 1-33	49
	25 A-16	50

A	18 1-41
	17 11-35
	16 11-25
	15 1-31
	14 9-2
	13 11-20
	12 5-63
	11 9-1
	10 5-72
	9 8-14
	8 2-2
	7 5-71
	6 1-14
	5 11-4
	4 3-2
	3 5-12
	2 11-31
	1 3-1

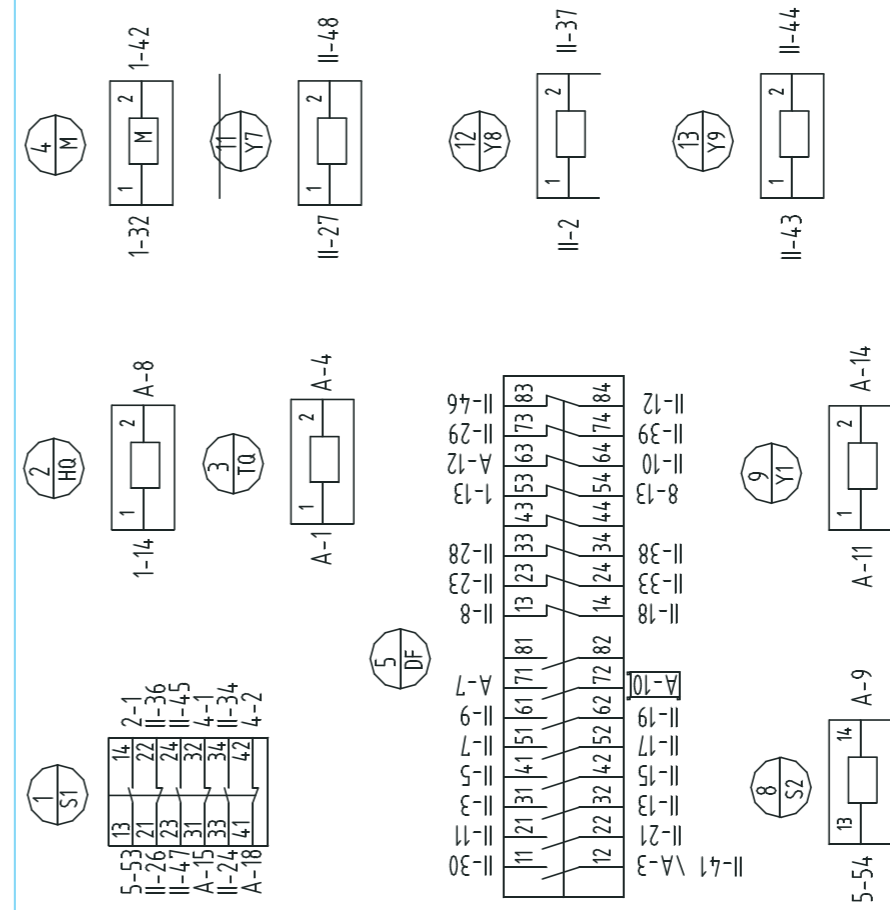

注：取消防跳功能方法：拔下A-10A接线即可：→cancel the anti jump function method just take out A-10 wiring

4	S1, 储能用微动开关 (Stored energy sensitive switch)	8	Y7~Y9 过电流脱扣器 (Over-current release)
3	QF: 与断路器主触头相连的辅助开关 (Auxiliary switch linked with principal axis of circuit breaker)	7	M: 储能电机 (Stored energy motor)
2	HQ: 合闸电磁铁 (Switching/on electromagnet)	6	I: 线路板接线端子 (Circuit boards terminal block)
1	TQ: 分闸电磁铁 (Switching/off electromagnet)	5	II: 断路器二次出线端子
序号 (Serial No.)	名称 (Description)	序号 (Serial No.)	名称 (Description)

图8 固定式断路器内部接线图 (带闭锁、带防跳、带防跳、过流)
Chart 8 the contacting drawings of fixed circuit breaker

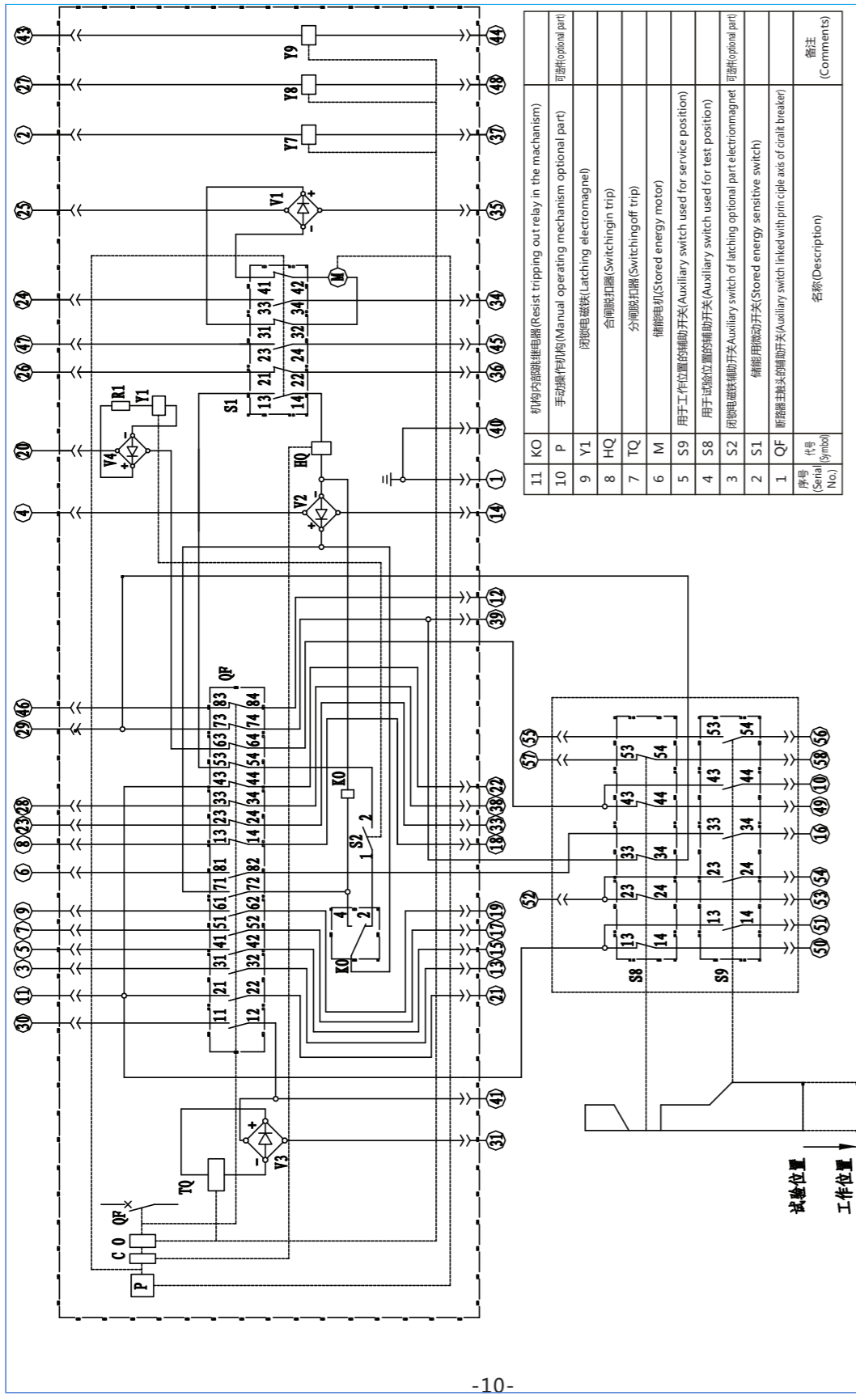

11	KO	机构内部脱扣线圈 (Resist tripping out relay in the mechanism)	可选件 (optional part)
10	P	手动操作机构 (Manual operating mechanism optional part)	可选件 (optional part)
9	Y1	闭锁电磁铁 (Latching electromagnet)	
8	HQ	合闸脱扣器 (Switching in trip)	
7	TQ	分闸脱扣器 (Switching off trip)	
6	M	储能电机 (Stored energy motor)	
5	S9	用于工作位置的辅助开关 (Auxiliary switch used for service position)	
4	S8	用于试验位置的辅助开关 (Auxiliary switch used for test position)	
3	S2	闭锁电磁铁辅助开关 (Auxiliary switch of latching optional part electromagnet)	可选件 (optional part)
2	S1	储能用微动开关 (Stored energy sensitive switch)	
1	QF	断路器主触头的辅助开关 (Auxiliary switch linked with principle axis of circuit breaker)	
		序号 (Serial No.)	代号 (Symbol)
		名称 (Description)	备注 (Comments)

图9抽出式断路器内部电气原理图 (带闭锁、带防跳、带防流、过流)
Chart 9 the inertior electric principle chart of draw-out type circuit breaker

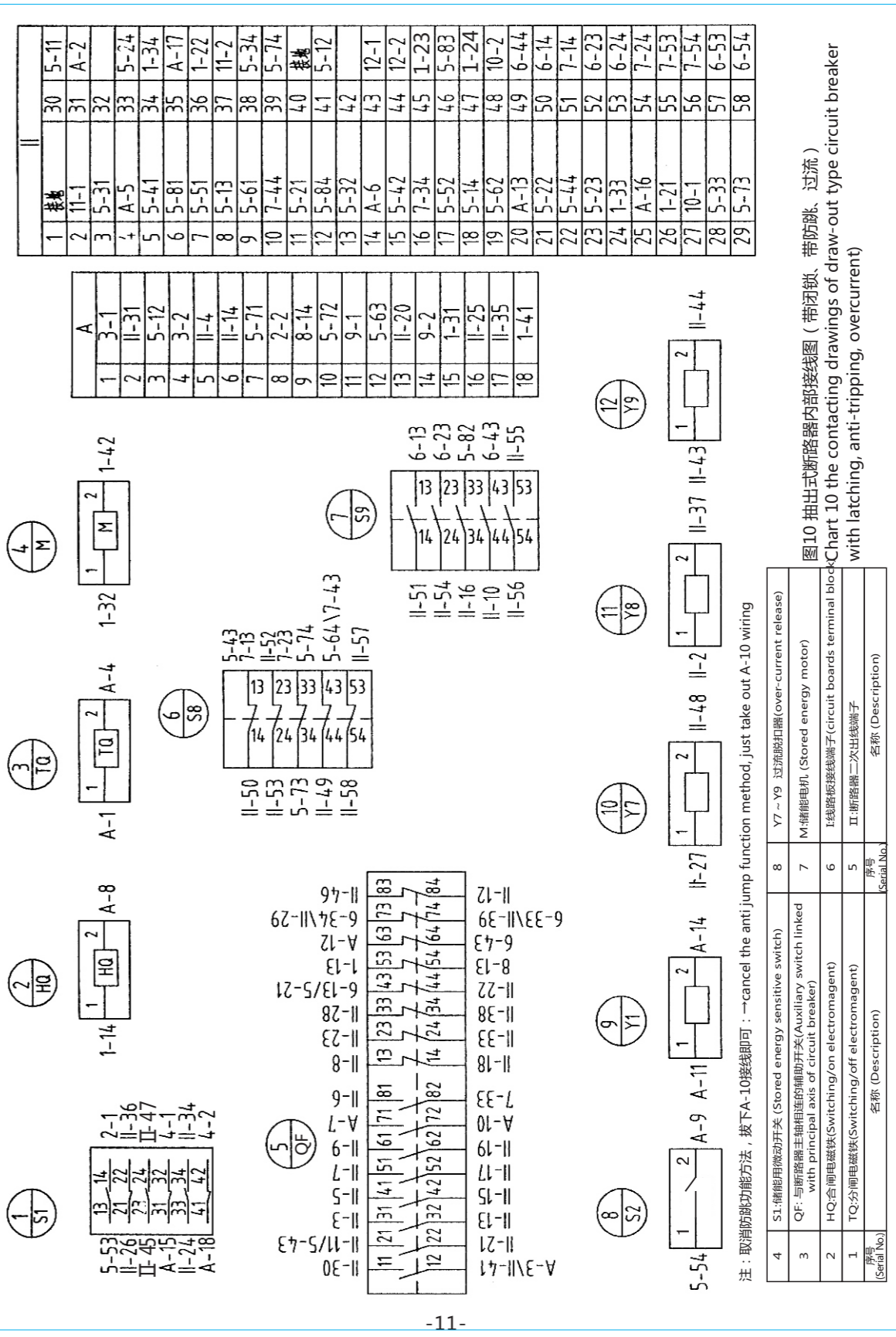

注：取消防跳功能方法，拔下A-10接线即可；取消过流防跳功能，取消A-10接线即可；取消过流防跳功能，取消A-10接线即可。

4	S1	储能用微动开关 (Stored energy sensitive switch)	8	Y7 - Y9	过流脱扣器 (over-current release)
3	QF	与断路器主触头相连的辅助开关 (Auxiliary switch linked with principle axis of circuit breaker)	7	M	储能电机 (Stored energy motor)
2	HQ	合闸电磁铁 (Switching on electromagnet)	6	比接线板接线端子 (circuit boards terminal block)	
1	TQ	分闸电磁铁 (Switching off electromagnet)	5	II 断路器二次出线端子	
		名称 (Description)			

图10 抽出式断路器内部接线图 (带闭锁、带防跳、带防流、过流)
Chart 10 the contacting drawings of draw-out type circuit breaker with latching, anti-tripping, overcurrent)



图11抽出式断路器内部电气原理图 (不带闭锁、带防跳、过流)

Chart 11 the inertior electric principle chart of drawer type circuit breaker (with latching, anti-tripping, overcurrent)

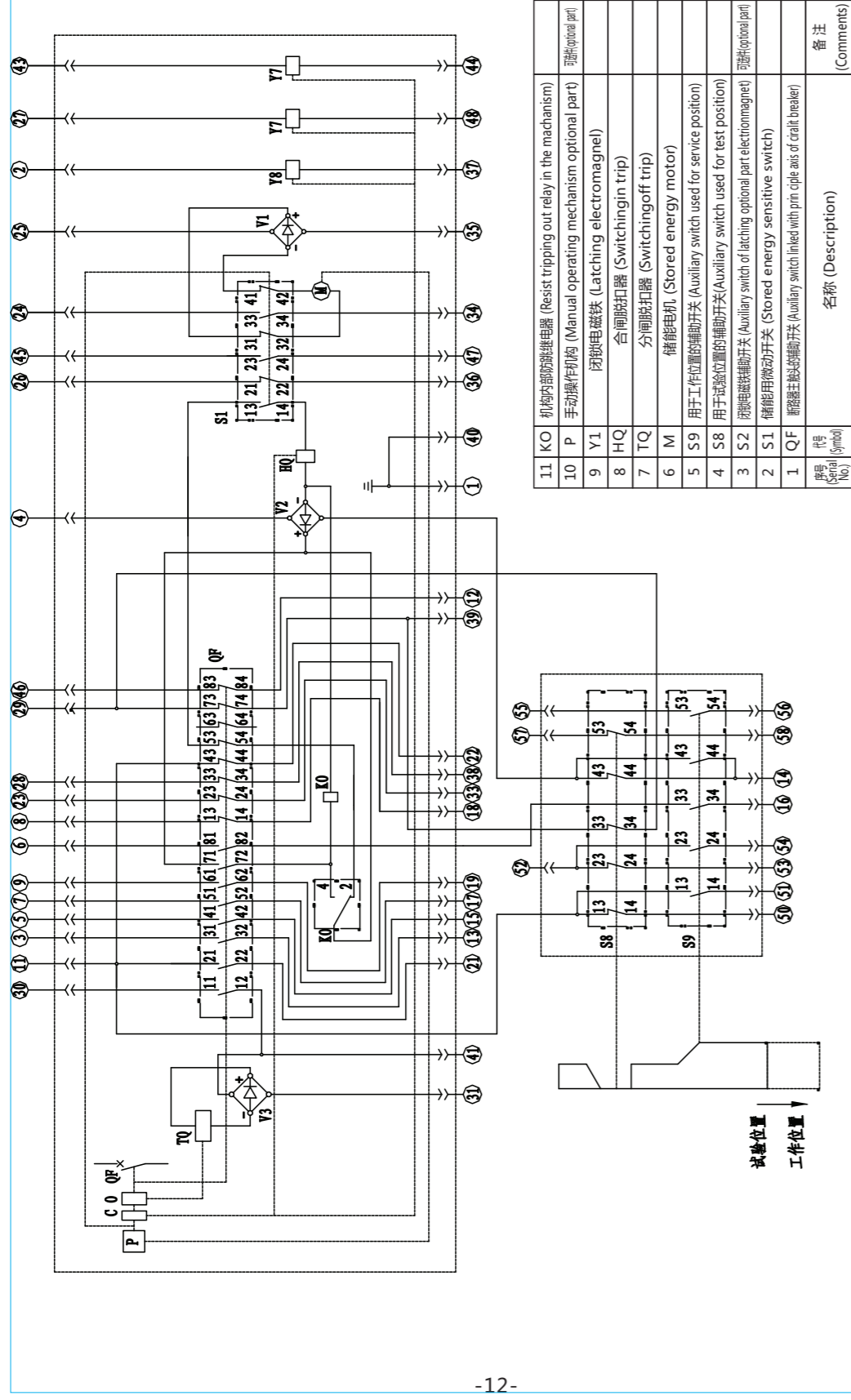
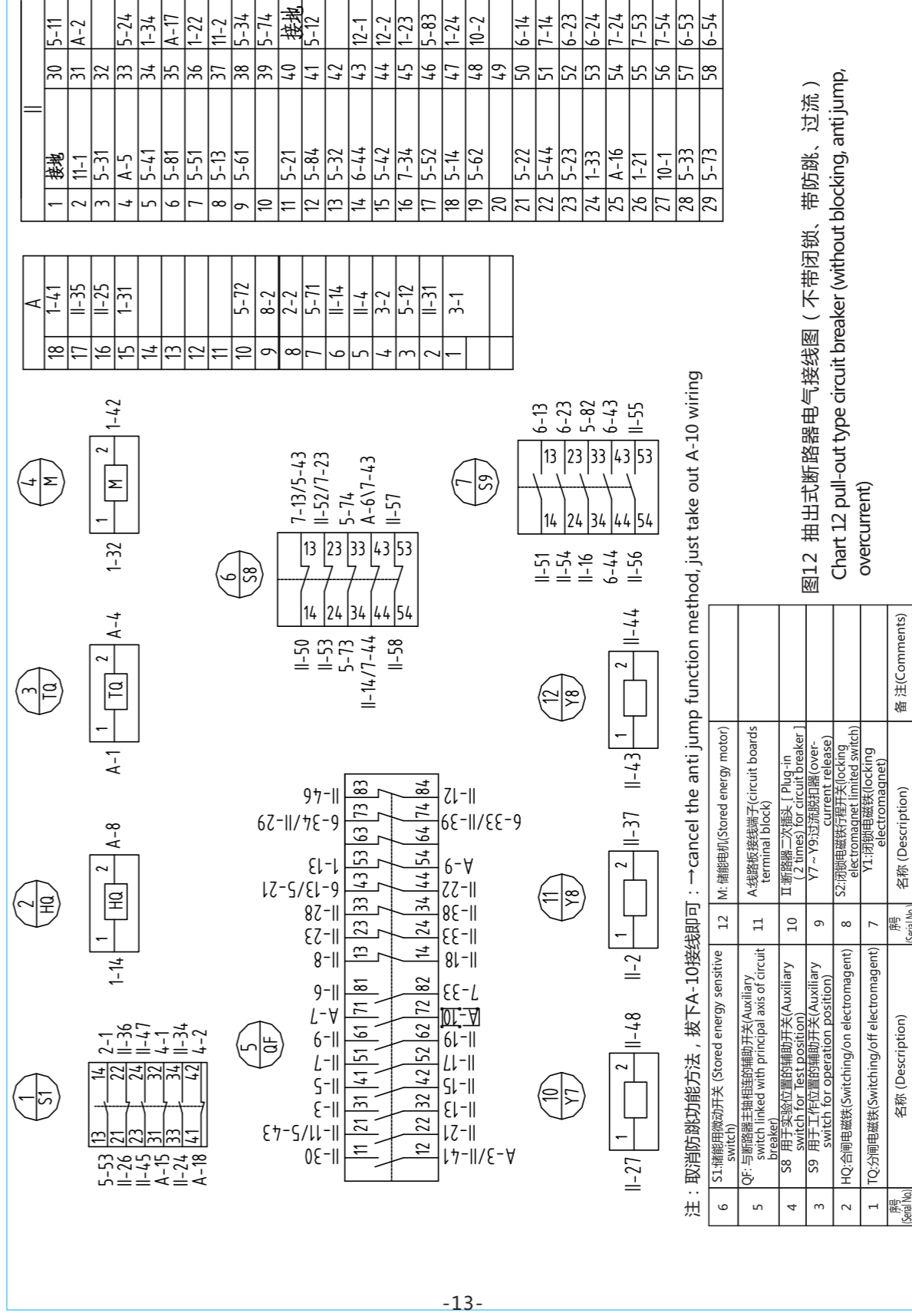

注：取消防跳功能方法，拔下A-10接线即可；取消储能电机功能方法，取消A-12接线即可。

图12 抽出式断路器电气接线图 (不带闭锁、带防跳、过流)

Chart 12 pull-out type circuit breaker (without latching, anti jump, overcurrent)

10 使用与维护(Operationse and maintenance) :

10.1 安装前检查(Checking before installation) :

断路器开箱后,应检查固定真空灭弧室的绝缘筒有无破裂,产品铭牌,合格证是否与订货单相符,装箱清单是否与实物相符,完好无误后再清理表面灰尘污垢,用工频耐压法检查真空灭弧室的真空度(开关分闸,在断口施加工频电压42kV-分钟)。→After unpackage,user should check the insulation canister of vacuum arc extinction room that has been broken or not, if the product nameplate and passed ecrтификаtion accord with the order for goods or not, the packing list accord with the actual or not After checking then clean the surface dust, and check the degree of vacuum of vacuum arc extinction room by power frequency withstand voltage method (cut off switch and put on power frequency voltage 42 kV a minute on fracture)

10.2 产品维护保养方法及注意事项(Maintenance method and notice term) :

a.断路器投入运行之前,应仔细核对各操作元件的额定电压(或电流),与实际情况是否相符,并用机构所具有的储能,合闸方式进行试操作,以检查各项指标是否正确。→Before the circuit breaker going to work,user should check carefully wirh the rated voltage or current accord with the actual or not.

b.断路器在使用过程中,应定期用工频耐压法检查真空灭弧室的真空度,具体方法是,将断路器分闸,在灭弧室断口间施加42kV工频电压,维持一分钟,灭弧室内不应有持续击穿,如发现灭弧室内有持续击穿,则真空灭弧室已失效,该断路器将不能再投入使用。→During the using of circuit breaker,user should check the egree of vacuum of vacuum arc extinction room by power frequency withstand voltage method termly.The detailed method is following:put on power frequency voltage 42kV a minute on fracture of vacuum arc extinction room, and the vacuum arc extinction room should not be brokendown continuously. If the vacuum arc extinction room has he brokendown continuously, the vacuum arc extinction room is disabled and not be used no more.

c.正常运行的断路器应定期维护清除绝缘件表面灰尘,所有磨擦部位应定期注润滑油。→User should maintain and clear the dust on the insulation object's surface of the normally running circuit breaker termly. All friction parts should add lubricating oil termly.

d.安装和使用时严禁用坚硬的物体撞击真空灭弧室外壳。→ No using rigid things impact the hull of vacuu arc extinction room when istallation and using.

e.用户不应随意更换使用与原型号规格不一致的电器元件。→ User shouldn't replace other electrical element different with original type optionally.

f.操作人员应初步了解机构的结构,性能及安装调整,维护检修知识,对运行中问题应予以记录必要时可通知制造厂家。→ Operator should realize primary the Structure, characteristic, installation and maintenance. If there are any questions in working, user must record in and advice to manufacturer.

11 运输与储存(Transportiation and store) :

11.1 运输(Transportation) :

a.ZN73 (VS1) 真空断路器运输时必须整台装入封闭的包装箱内加以固定。→ ZN73 (Vs1) vacuum circuit breaker must be pack in an closed package and fixed during the transportation.

b.装箱,开箱和保管应在干燥的室内,对产品及各部件要进行核对是否完整和相符。→ Packing,unpackage and keeping should be done in the dry indoor, Check the product and its parts is complete and right or not.

11.2 储存(Store)

断路器应存放在干燥、通风、防潮,防振及防有害气体侵蚀的室内,长期存放应在传动部分涂润滑油,并定期检查环境是否符合要求。真空灭弧室允许储存期为20年。→The circuit breaker should be stored indoor which is dry, ventilative, moistureproof and anti-corrading of harmful gas. Longterm store should daub lubricant on the gearing, and check the circumstance met the require yes of not termly.

12 随机文件(Documents together) :

- 产品合格证书→Product passed certification
- 出厂检验报告→Exw check report
- 安装使用说明书→Installation and use specification
- 装箱单→Packing list

13 订货须知(Order notice) :

用户在订货时应注明(User must give clear indication of the followings when make a order:) :

- 断路器型号,名称及订货数量。→Typer, name and quantity of circuit breaker
- 断路器额定电压,额定电流及额定短路开断电流。→ Rated voltage, current and rated short circuit breaking current rated operating voltage
- 额定操作电压。→Reted operating voltage
- 备品,备件的名称及数量。→name and quantity of spare part
- 用户若有其它特殊要求,可在订货时说明。→have other special requires, please notice during the orrder.